AN INTELLIGENT ONE HOUR MULTICHARGER FOR Li-Ion, NiMH and NiCd BATTERIES

by J-M. Ravon and L. Wuidart

INTRODUCTION

An increasing number of cordless and portable appliances are powered by rechargeable batteries. Products such as portable audio equipment, mobile phones, and cordless power tools illustrate the enormous contribution which rechargeable batteries make to our comfortable lifestyle. As equipment becomes lighter and more compact, battery performance must follow suit, hence NiMH batteries have overtaken NiCd batteries, due to their superior capacity for a given weight and size.

More recently, the new Li-Ion battery technology has been used on camcorders, and will soon spread to other applications. Other new battery technologies, such as Zinc-Air, are already appearing on the market.

Rapid charging of NiCd and NiMH batteries in one hour or less is already commonplace. Many battery chargers already cope with both these battery types and, in future, chargers will have to be compatible with emerging battery technologies.

This paper presents a new multicharger concept which is fully compatible with Li-Ion, NiCd and NiMH. Moving from NiCd/NiMH to Li-Ion technology is easy when battery charging is monitored by a flexible industry standard 8-bit microcontroller.

A ONE HOUR MULTICHARGER CONCEPT...

In this example of an intelligent one hour multicharger, the battery is charged by a constant current source while an industry standard 8-bit microcontroller monitors both battery voltage and temperature, using its on-chip Analog to Digital converter as illustrated in Figure 1-1.

Figure 1-1. Intelligent multicharger concept: Li-Ion/NiCd/NiMH compatibility is ensured by an SGS-THOMSON low-cost 8 bit microcontroller.

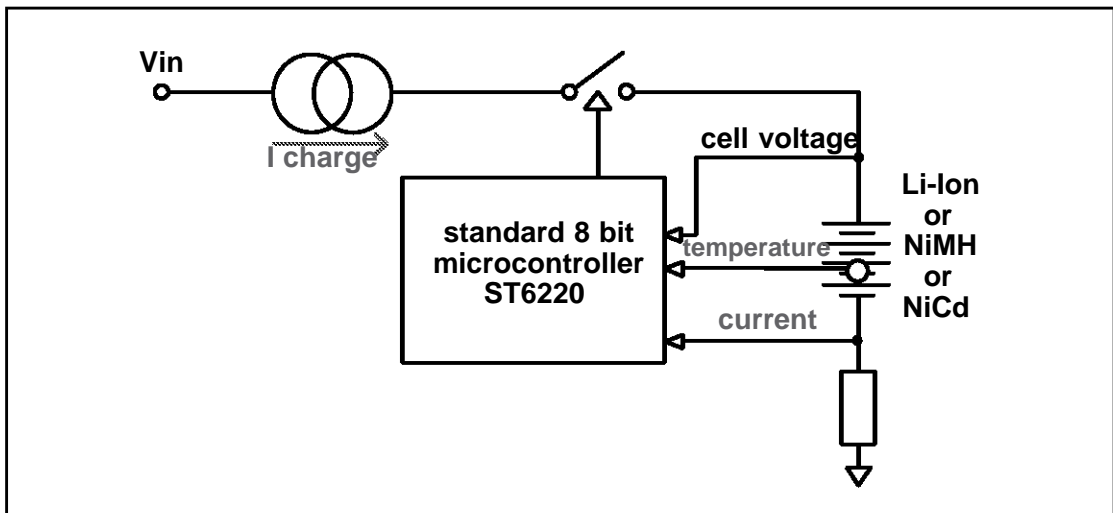

The key to the charging methods used to ensure compatibility with different battery technologies, is the ability to monitor the charging parameters using a low-cost industry standard SGS-THOMSON 8-bit microcontroller: the **ST6220**. The inherent programmability of a microcontroller based charger concept allows the existing NiCd/NiMH design [1] to be upgraded for use with the new Li-Ion rechargeable batteries, simply by modifying the software, while retaining the same hardware design.

Safe charging is ensured by combining several termination methods, guaranteeing results on a par with high-end dedicated monitoring circuits. These back-up termination criteria can be optimised by software for any specific application requirement. For example, the termination criteria can be easily adapted by software to specific cell technologies or to dedicated battery pack shapes.

The intrinsic adaptability to new battery technologies and charging methods represents a major benefit with respect to dedicated solutions.

1 NiCd AND NiMH FAST CHARGING

Safe fast charging relies on the charging cycle being monitored intelligently. This has already been successfully achieved in a design based on a standard ST6220 low-cost 8-bit microcontroller. This charger design is capable of charging both NiCd and NiMH batteries, using a charge termination method based on detecting the inflexion point in the battery voltage curve.[1]

However, sophisticated termination methods, such as inflexion point detection, require battery voltage measurement with a resolution of at least 10 bits. This can be achieved by using an external operational amplifier to improve the resolution of the on-chip 8-bit Analog to Digital converter [1].

A cheaper means of obtaining high resolution voltage measurement lies in measuring the charge time of a capacitor, using the microcontroller's on-chip timer.

A simple RC circuit (using a polyester capacitor for its temperature stability), connected to a triggered input port, allows battery voltage variations to be converted to time measurements, with an equivalent resolution of 11 bits.

Figure 1-2. RC charge time voltage measurement technique

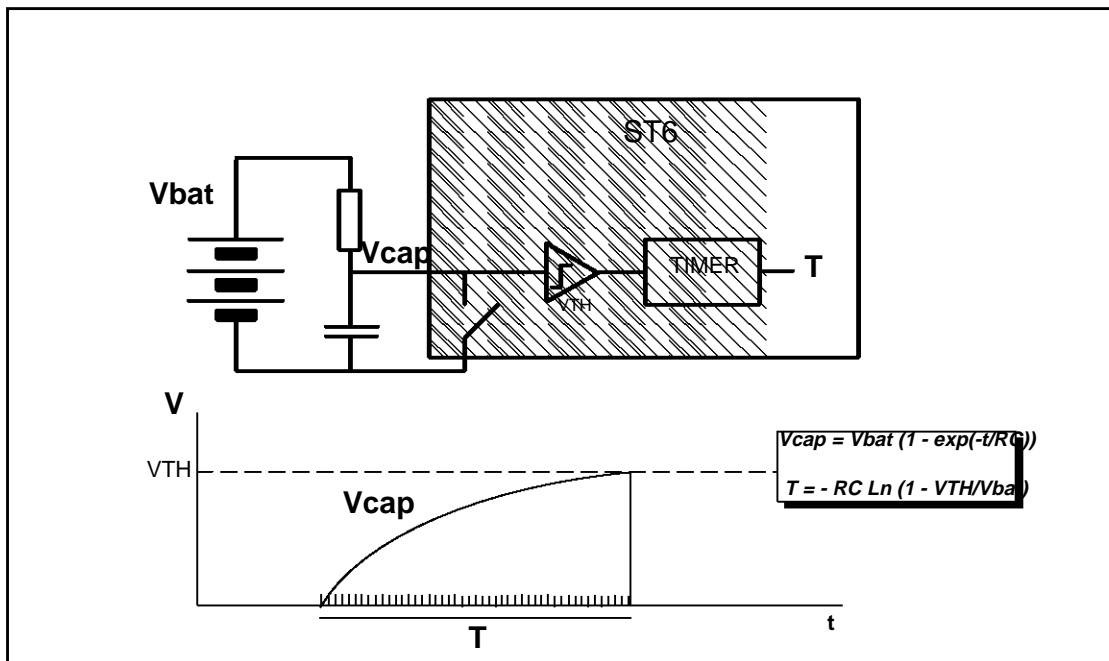

A ONE HOUR MULTICHARGER CONCEPT...

The effective resolution achieved using this technique has been measured as better than 11 bits, allowing more reliable detection of the inflexion point on the battery voltage curve.

Charge termination based on inflexion point detection improves NiCd/NiMH battery life, by avoiding excessive overheating. This avoids the user having to prematurely replace costly battery packs.

Safe charging, in one hour or less, is possible using this low-cost microcontroller design which combines three other back-up termination methods, worthy of high-end dedicated control circuits: $-\Delta V$ detection, battery temperature monitoring and timed shutdown.

Figure 1-3. Safe charging of NiCd and NiMH batteries is ensured by combining three back-up termination methods: $-\Delta V$ detection, battery temperature monitoring and timed shutdown.

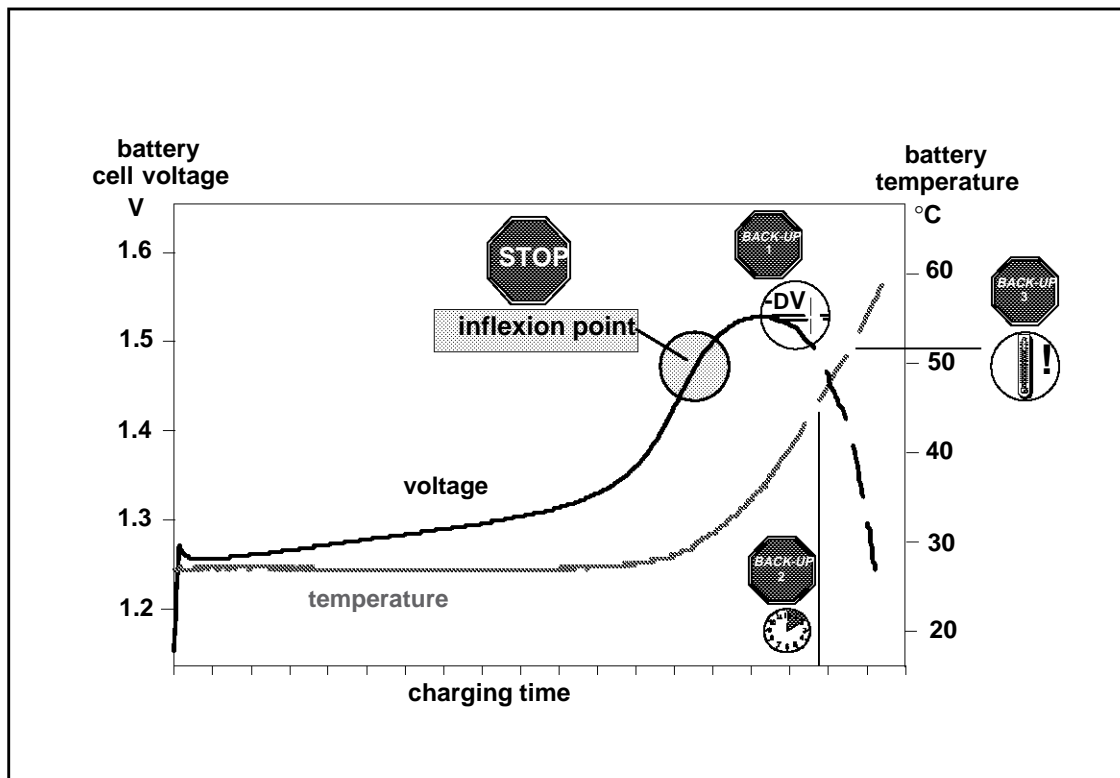

2 EXTENDING THE CONCEPT TO Li-Ion

The inherent programmability of such a microcontroller based charger concept allows it to be upgraded from the NiCd/NiMH version to cope with the new Li-Ion batteries.

Such a multicharger concept is fully Li-Ion/NiCd/NiMH compatible: charging any of these battery types becomes transparent to the user .

Li-Ion batteries can be charged using two different methods, both of which are easily monitored by means of an industry standard low-cost 8-bit microcontroller.

In the **conventional** method, charging begins under constant current conditions.

Once a specified battery voltage (4.2V) has been reached, the charger applies a regulated constant voltage to the Li-Ion cell (C1 phase in Figure 1-4.).

Current thus decreases as charging proceeds, until current flow ceases when full capacity is reached, preventing overcharging (C2 phase in Figure 1-4.).

Figure 1-4. Conventional Li-Ion charging method:

- C1 phase: constant current charge
- C2 phase: decreasing current charge

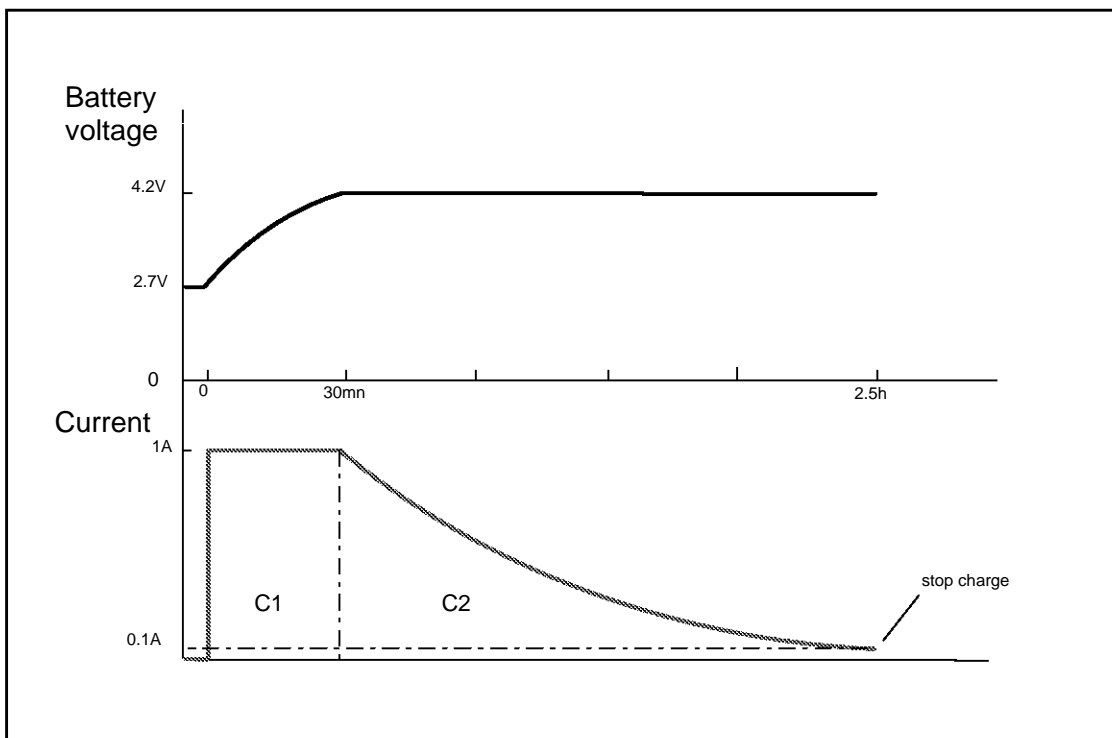

A ONE HOUR MULTICHARGER CONCEPT...

Although a 1 Ah NiCd/NiMH battery pack is fully charged in one hour with a 1 Amp output charger, it will take 2.5 hours to complete the charge of the corresponding Li-Ion 1Ah pack as can be seen in Figure 1-5.

An alternative technique consists in using a constant current source, just as in NiCd/NiMH battery chargers.

This new **Li-Ion** method may be applied because the capacity level is known during the entire charging process. Once this “capacity level” indicates full charge, the monitoring microcontroller stops the constant current flow, thus avoiding any overcharging.

Such a constant current source based charging method has an obvious benefit, when one hour charging is required. To reach full capacity in a 1 Ah Li-Ion pack in one hour, a charger must deliver twice the output power using a conventional method, compared to a constant current source method.

Referring again to our 1 Ah battery example, a “Conventional one hour multicharger” must deliver 2 Amps for 20 minutes in order to reach full capacity of the Li-Ion battery, whilst NiMH/NiCd batteries require only 1 Amp to be fully charged under the same conditions, as can be seen in Figure 1-6.

Figure 1-5. A 1 Amp output multicharger will reach full capability of 1Ah pack in:
- in 1 hour for NiCd and NiMH batteries
- in 2.5 hours for Li-Ion batteries

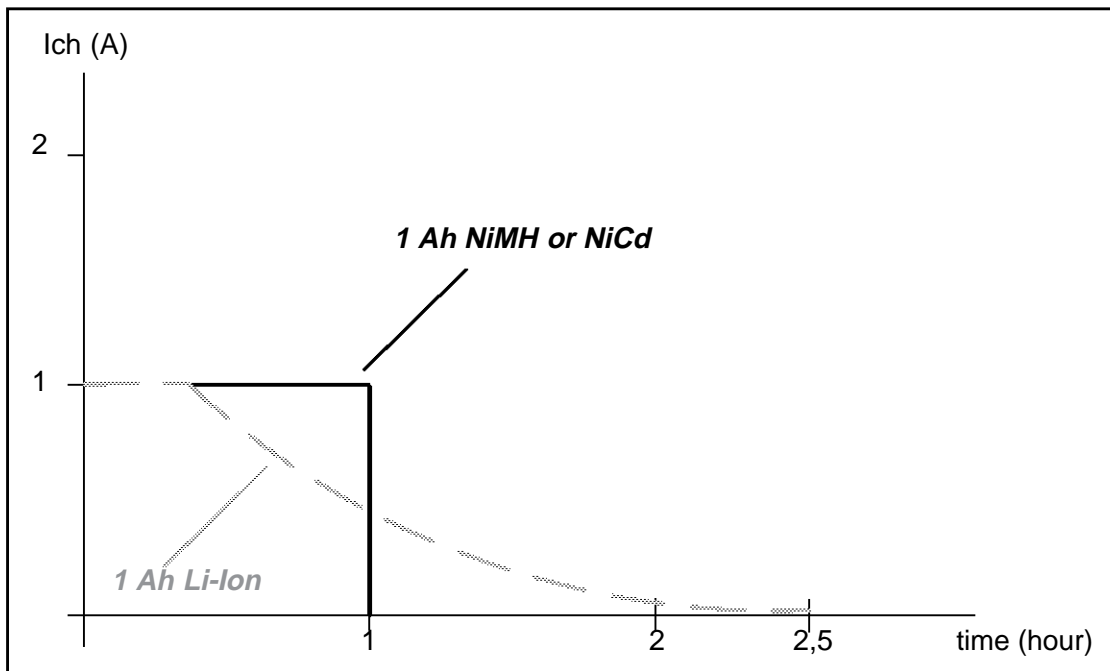

Figure 1-6. To reach full capacity of a 1 Ah Li-Ion pack in one hour, a multicharger must deliver twice the output power with a conventional method, compared to a constant current source method.

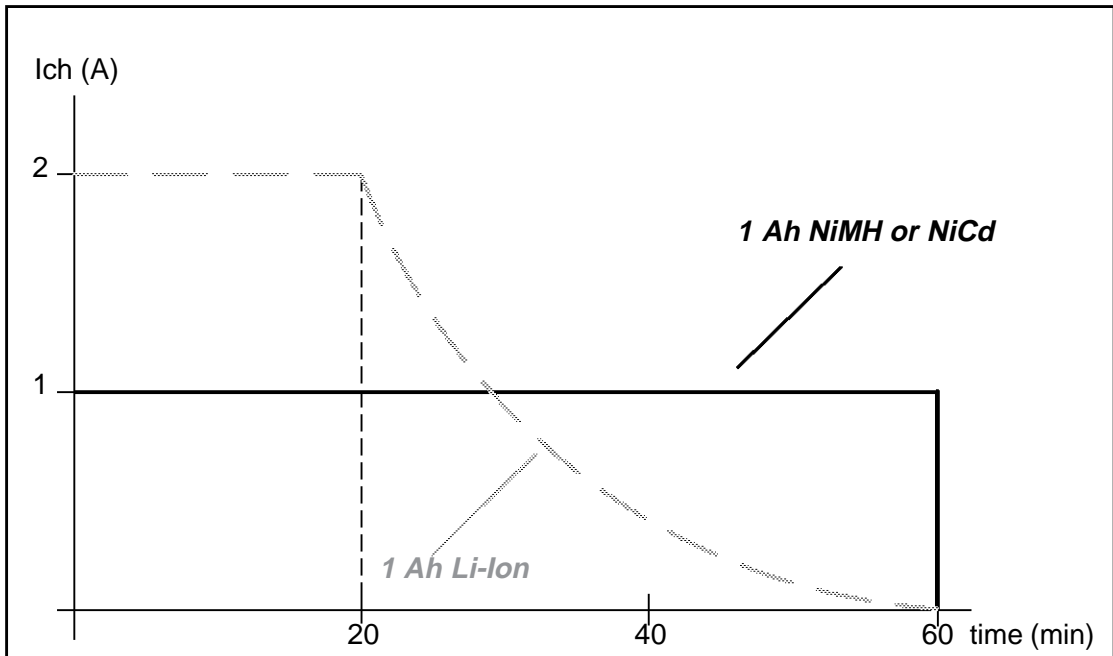
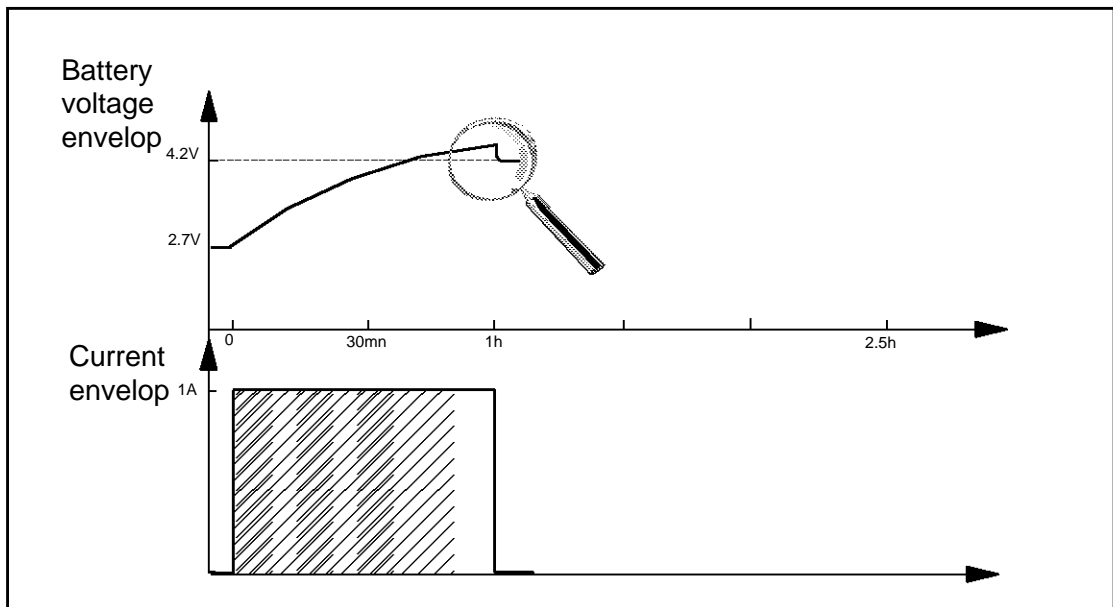

Figure 1-7. New Li-Ion charging method using a constant current source charger: battery voltage and current envelopes



A ONE HOUR MULTICHARGER CONCEPT...

This *new* charging method is based on measurements of the Li-Ion cell voltage under “no charge” conditions, i.e. when charging current is stopped. The value of this “no charge” Li-Ion cell voltage gives a good indication of the charge capacity level.

Since a 4.2V “no charge” voltage corresponds to a fully charged battery, charging is stopped as soon as the “no charge” voltage reaches 4.2V, as can be seen in Figure 1-7.

To measure this “no charge” battery voltage, the charging current delivered by the switchmode power supply is interrupted by the microcontroller every 20 seconds, as can be seen in Figure 1-8.

The “true” value of the “no charge Li-Ion cell voltage” is measured by the on-chip 8-bit Analog to Digital converter, some seconds after interrupting the charging current, to allow the battery to recover.

Under charging current conditions, the Li-Ion cell voltage can be higher than 4.2.V (reaching for example 4.4.V), mainly because of the additional voltage drop due to its internal resistance.

This additional voltage drop does not lead to overcharge of the Li-Ion battery.

Figure 1-8. To measure “no charge” battery voltage, the charging current delivered by the switching power supply is interrupted by the microcontroller every 20 seconds.

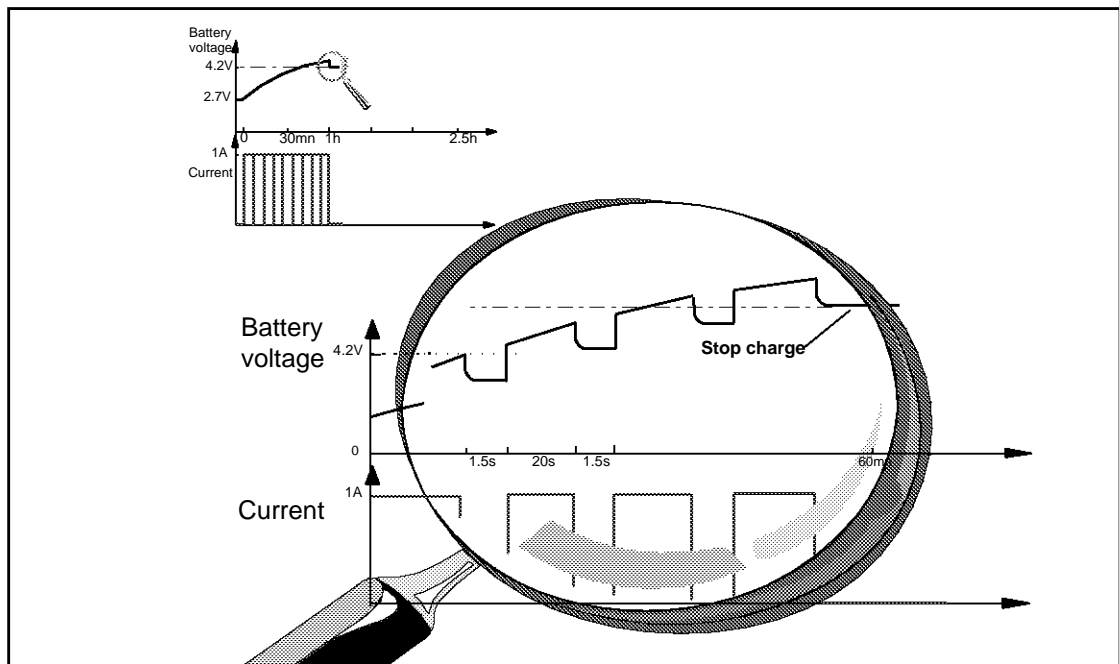

LI-ION VOLTAGE CALIBRATION

Whatever the charging method, for a Li-Ion cell, a 100 mV cell voltage difference represents in a change of more than 7% in cell capacity.

Since the absolute value of the Li-Ion cell voltage is used to stop the charging process, battery manufacturers recommend charging methods with an overall voltage accuracy of +/- 1%.

To achieve such an accuracy level, conventional discrete solutions require expensive components (0.2% resistors, 0.5% voltage references, etc...).

This microcontroller based multicharger concept offers a cheaper solution by using a voltage reference software calibration technique, as can be seen in Figure 1-9.

The microcontroller memory allows compensation of the voltage reference.

The voltage reference only needs to be temperature stable. For example, a standard UC3843 voltage reference circuit provides a temperature stability of 0.2 mV/°C, which is more than sufficient.

Calibration and memorisation of the Li-Ion reference battery voltage is carried out during factory testing.

Figure 1-9. The microcontroller memory allows Vref calibration.

Vref only needs to be temperature stable (UC3843 Vref has a sufficient temperature stability: 0.2mV/°C). Calibration and memorisation of the Li-Ion reference battery voltage is carried out during factory testing.

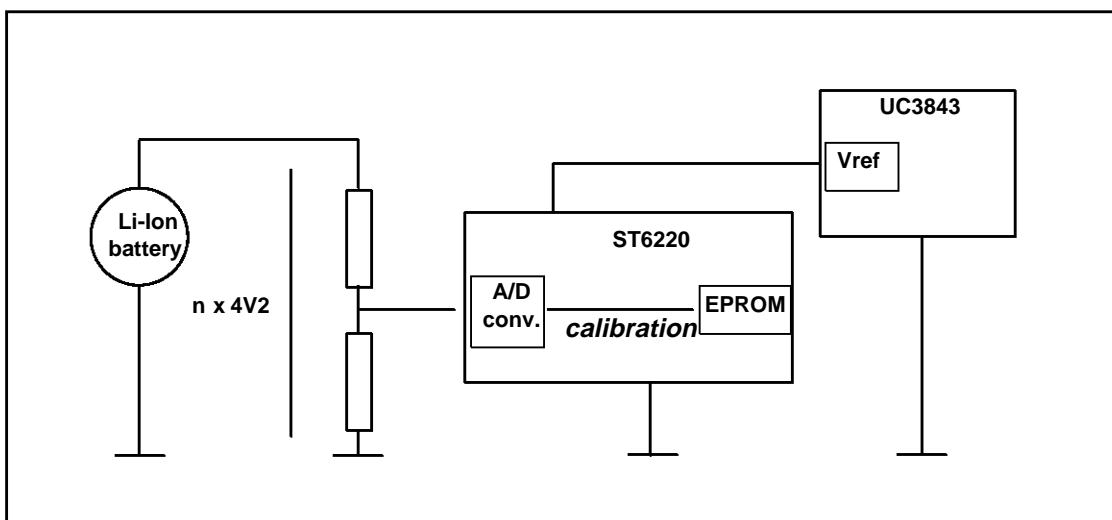

A ONE HOUR MULTICHARGER CONCEPT...

**Figure 1-10. Electrical diagram of the Li-Ion/NiCd/NiMH multicharger:
DC/DC 100 kHz SMPS/10 Watts**

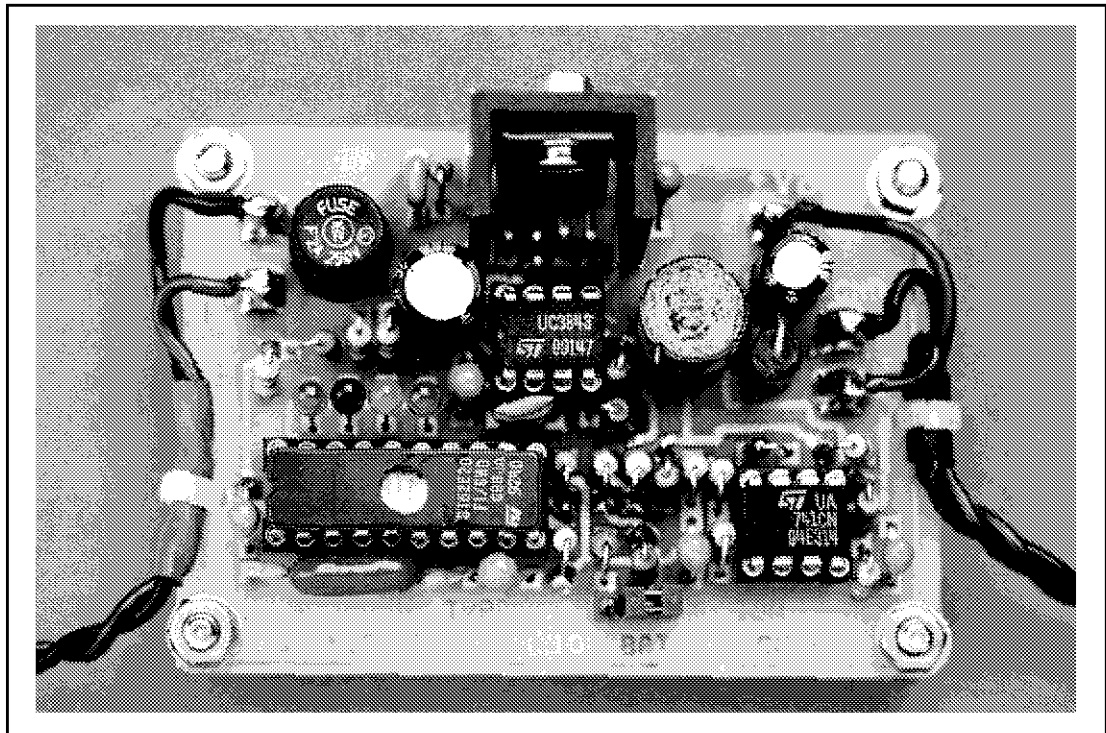
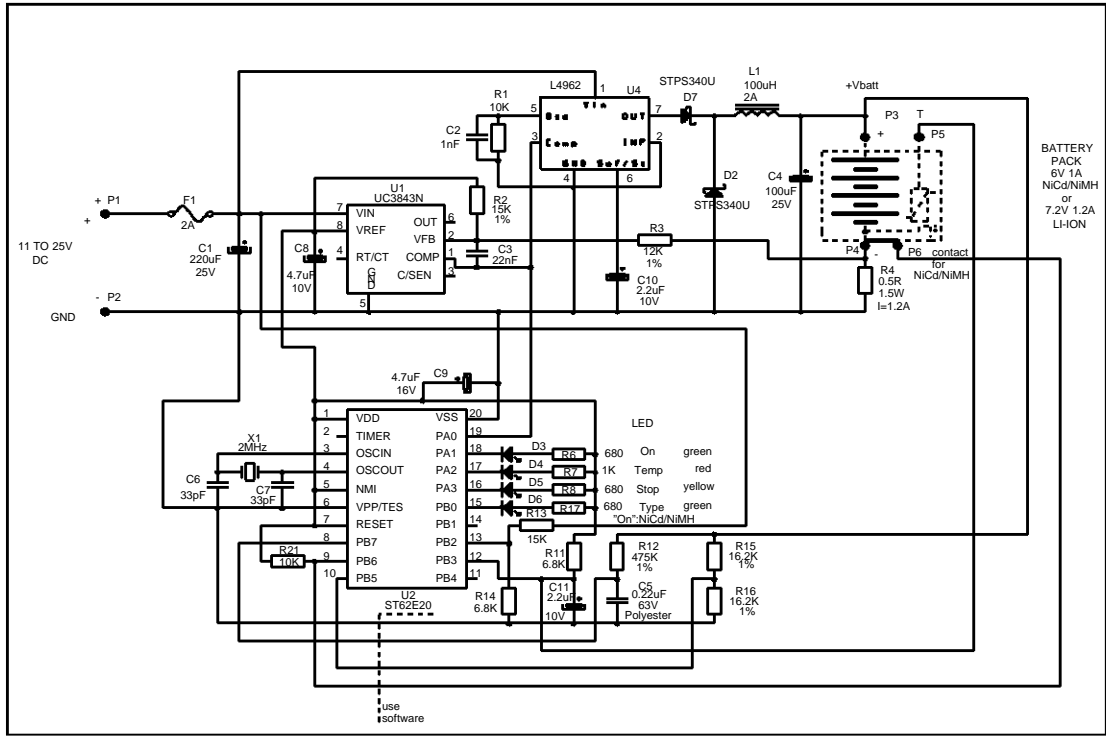

CONCLUSION

Li-Ion is an emerging battery technology because of its higher capacity for a given weight and size, compared to the latest NiMH rechargeable batteries. For this reason, the next generation of battery chargers must be fully Li-Ion/NiCd/NiMH compatible.

This paper describes an example of such an intelligent multicharger concept, using a DC/DC switch mode power supply providing a constant current to the battery pack as illustrated in Figure 1-10.

Battery type may be determined by means of sensing contacts on the battery pack which are read by I/O ports on the microcontroller.

The internal memory of this 8-bit standard microcontroller provides a cost effective calibration solution to achieve the high level of voltage accuracy required for Li-Ion charging.

The intrinsic programmability of such a microcontroller based charger has allowed an easy upgrade path from the previous NiCd/NiMH version [1] to the new Li-Ion rechargeable batteries, without major hardware changes.

Other charging and back-up termination methods can be easily implemented simply by modifying the control software, while retaining the same hardware design. This simplifies the design task compared to a fully dedicated control circuit. A standard microcontroller based approach can thus significantly reduce the overall design cycle time of battery chargers.

Software adaptability to new battery technologies and charging methods represents a major benefit compared to dedicated solutions.

The inherent flexibility of the microcontroller approach will allow rapidly evolving battery technologies, such as Zinc-Air or Zinc-Silver, to be catered for.

References:

[1] "From NiCd To NiMH Fast Battery Charger"

AN417/L.WUIDART, J. NICOLAI (SGS-THOMSON Microelectronics)

A ONE HOUR MULTICHARGER CONCEPT...

NOTES:

Information furnished is believed to be accurate and reliable. However, SGS-THOMSON Microelectronics assumes no responsibility for the consequences of use of such information nor for any infringement of patents or other rights of third parties which may result from its use. No license is granted by implication or otherwise under any patent or patent rights of SGS-THOMSON Microelectronics. Specification mentioned in this publication are subject to change without notice. This publication supersedes and replaces all information previously supplied.

SGS-THOMSON Microelectronics products are not authorized for use as critical components in life support devices or systems without express written approval of SGS-THOMSON Microelectronics.

©1996 SGS-THOMSON Microelectronics - Printed in Italy - All Rights Reserved.

SGS-THOMSON Microelectronics GROUP OF COMPANIES

Australia - Brazil - Canada - China - France - Germany - Hong Kong - Italy - Japan - Korea - Malaysia - Malta - Morocco - The Netherlands - Singapore - Spain - Sweden - Switzerland - Taiwan - Thailand - United Kingdom - U.S.A.